

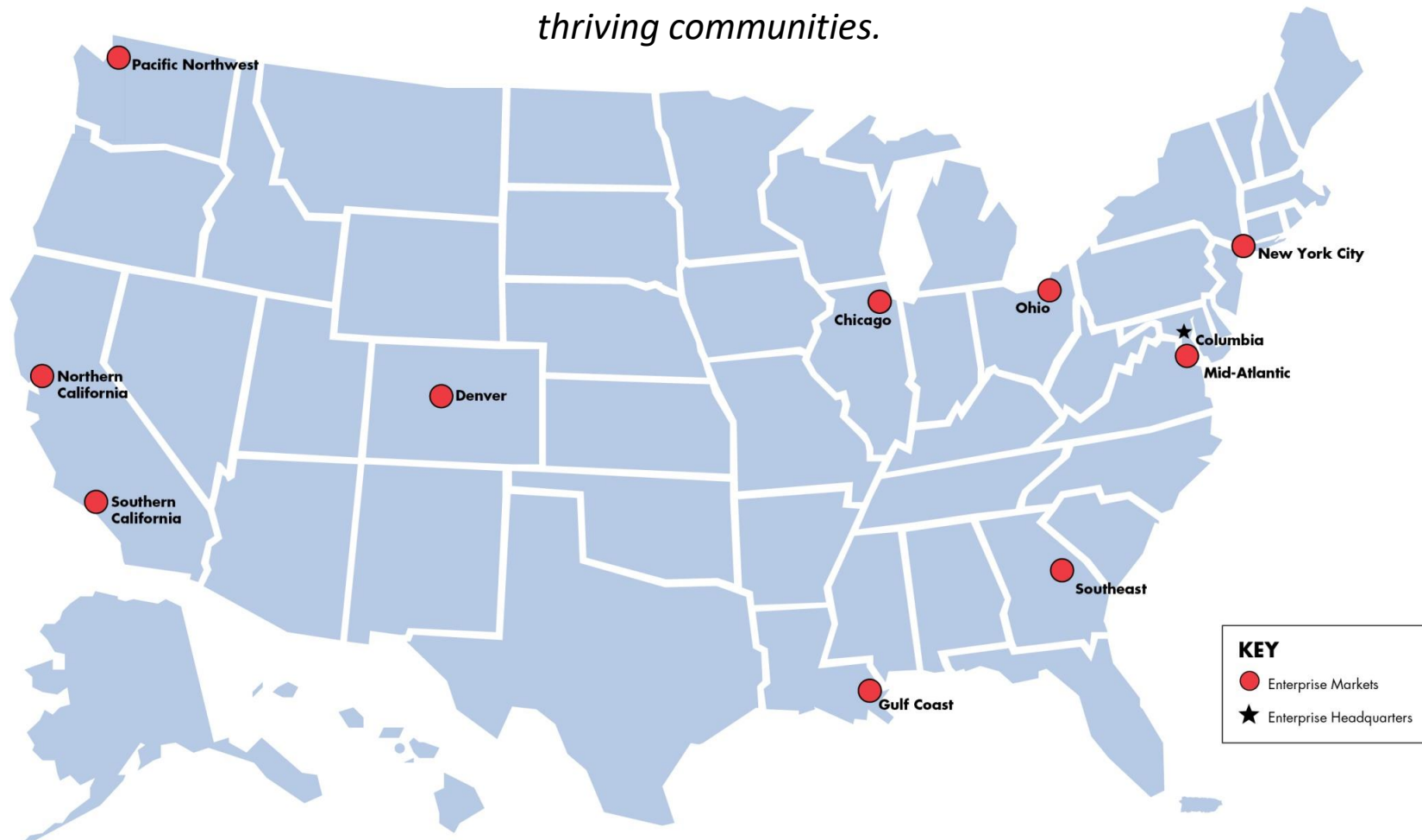

Preserving
Affordable
Housing From
Climate Risk

Enterprise: Who We Are

Create opportunity for low- and moderate-income people through fit, affordable housing in diverse, thriving communities.



Collaborating Partners: Federal, State, Local



Fannie Mae®



NATURAL
RESOURCES
DEFENSE
COUNCIL



USDN
urban sustainability
directors network



U.S. DEPARTMENT OF
ENERGY



Governor's Office of
Storm Recovery



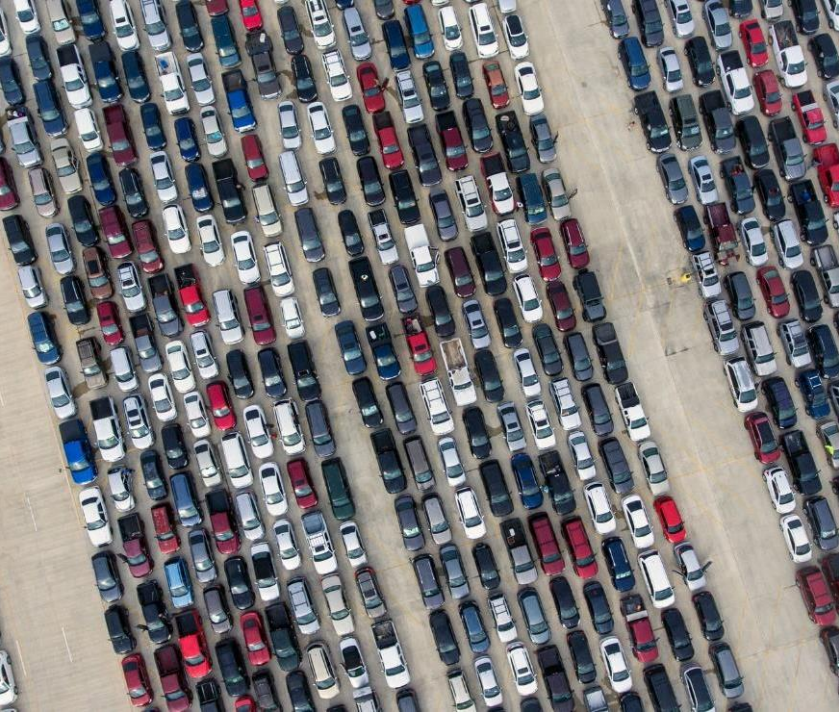

Extreme Shortage of Affordable Housing

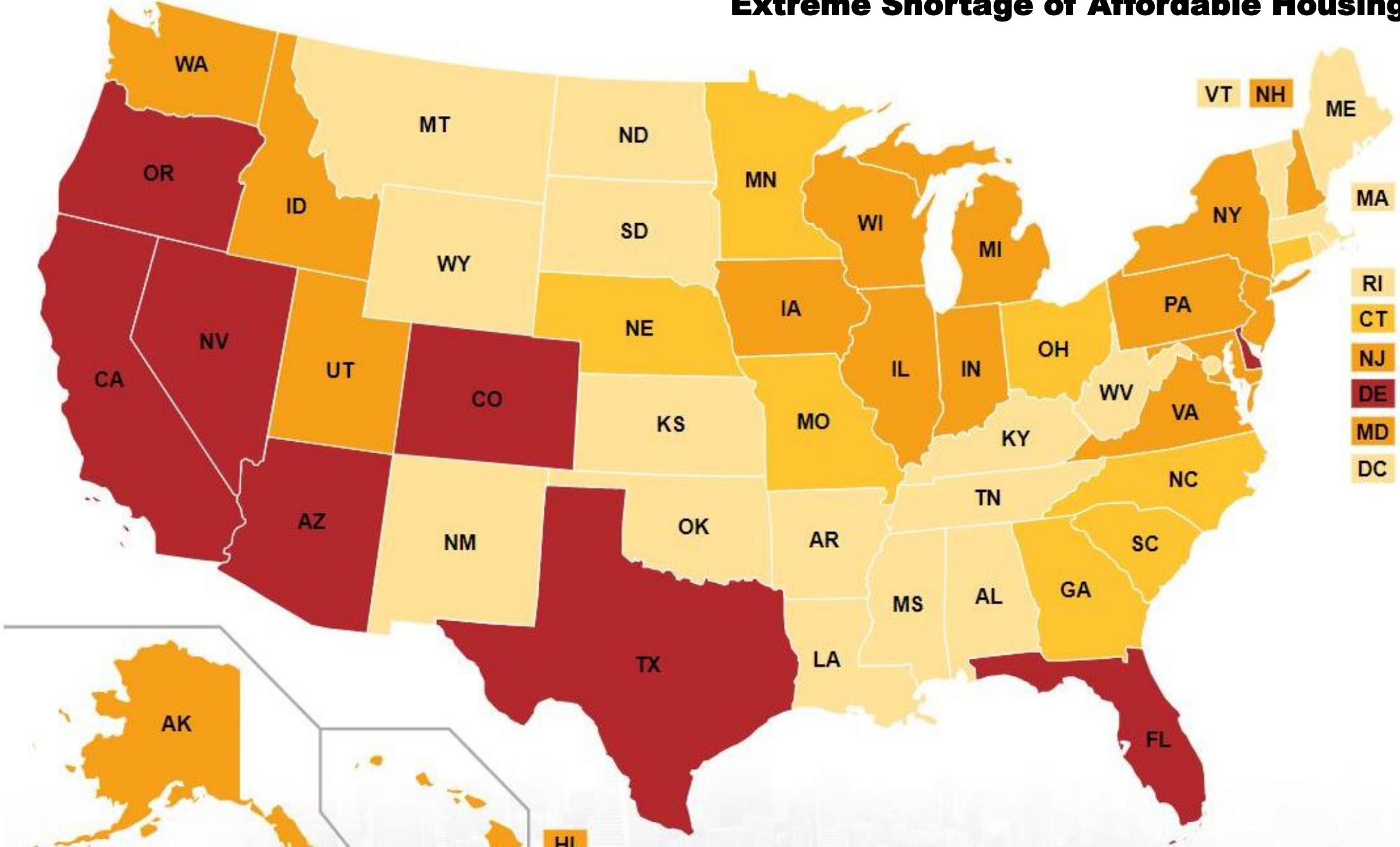





What are the Impacts?

- Loss of Affordable housing
- Displacement of Households;
- Impact to Workforce and Economy;
- Lowered property values;
- Lowered Tax Base

Superstorm Sandy



STRATEGIES FOR MULTIFAMILY HOUSING RESILIENCE

Community

Strategies that encourage behavior which enhances resilience.

Adaptation

Strategies that improve a facility's ability to adapt to changing climate conditions.

Protection

Strategies to reduce a building's vulnerability to extreme weather.

Backup

Strategies that provide critical needs when a facility loses power or other services.

READY TO RESPOND

Strategies for Multifamily Building Resilience Vol. 1



Disaster Preparedness
for Affordable
Housing Organizations

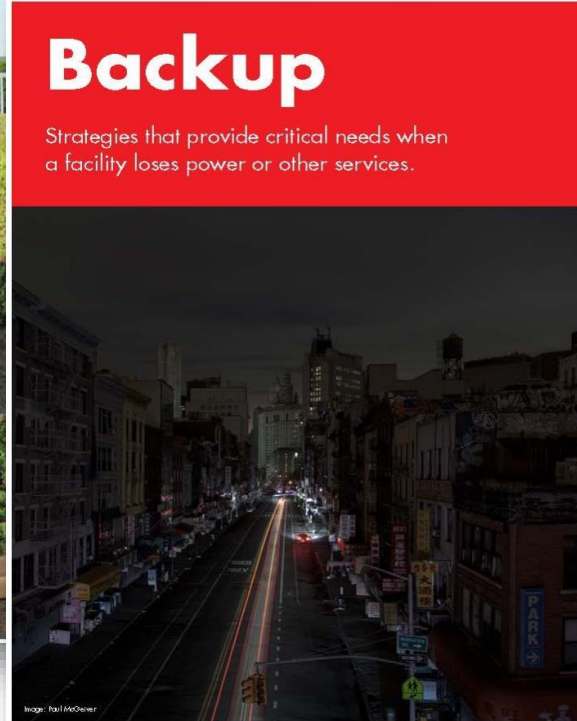
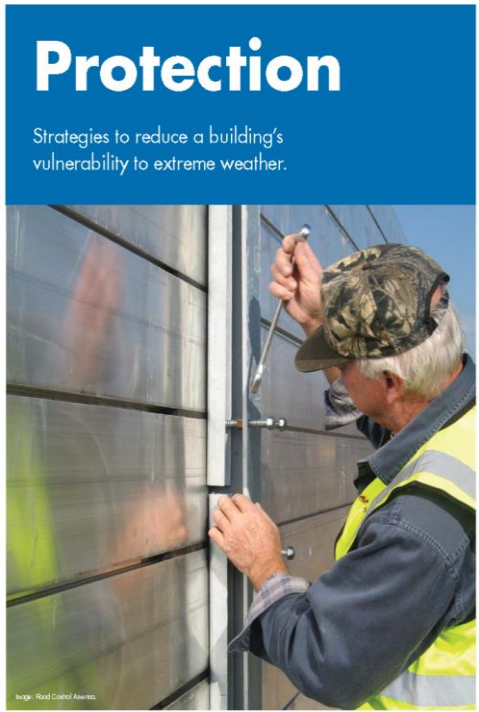
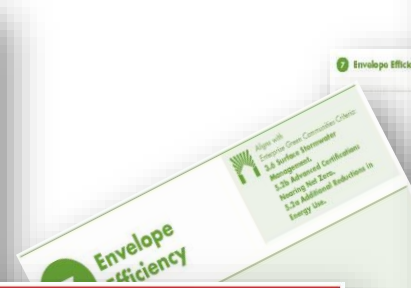

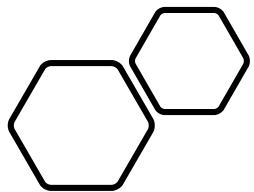

**Moxby Rigby
Freeport Public Housing**





KEEP SAFE

A GUIDE FOR RESILIENT HOUSING DESIGN IN ISLAND COMMUNITIES



MANTÉNGASE SEGURO

UNA GUÍA PARA EL DISEÑO DE VIVIENDAS RESILIENTES EN COMUNIDADES ISLEÑAS



KEEP SAFE

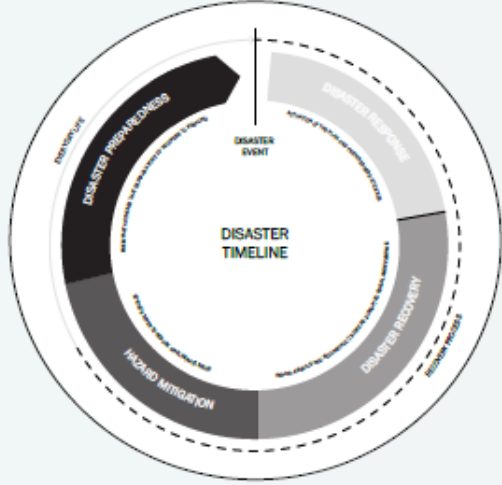

Introduction

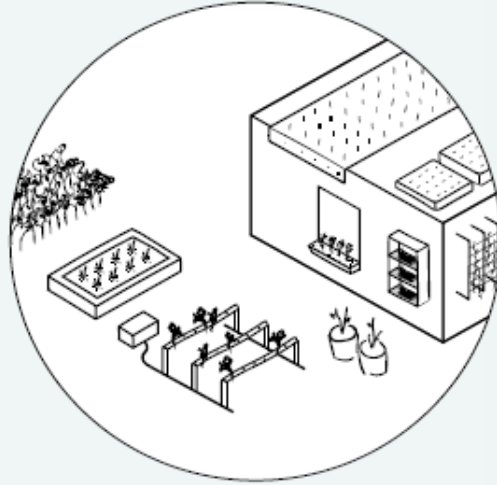

Chapter 1: A Safer Site

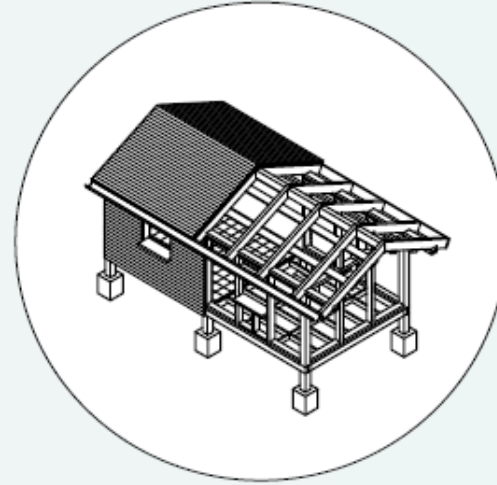

Chapter 2: Building Protection

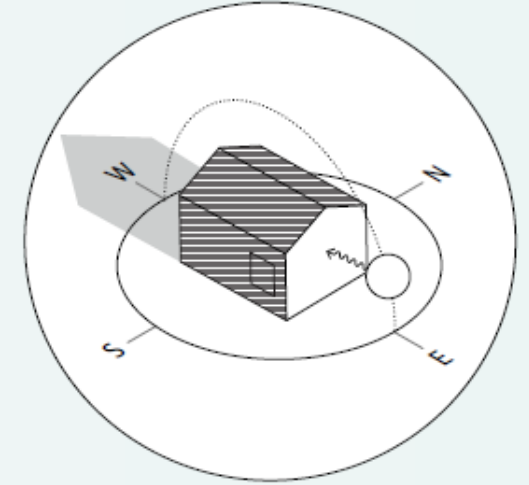

Chapter 3: Passive Habitability

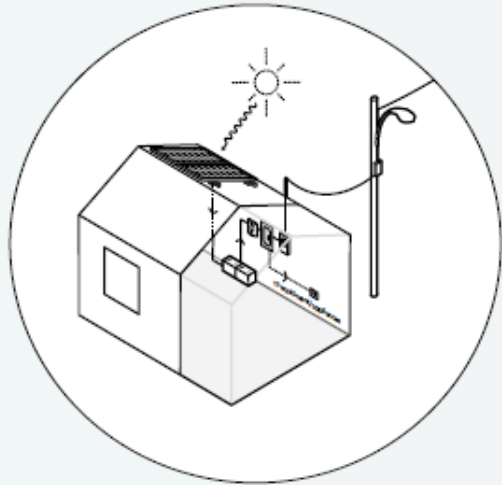

Chapter 4: Energy Generation

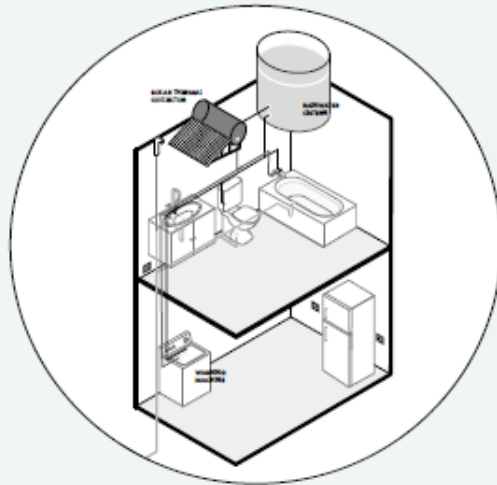

Chapter 5: Water Management

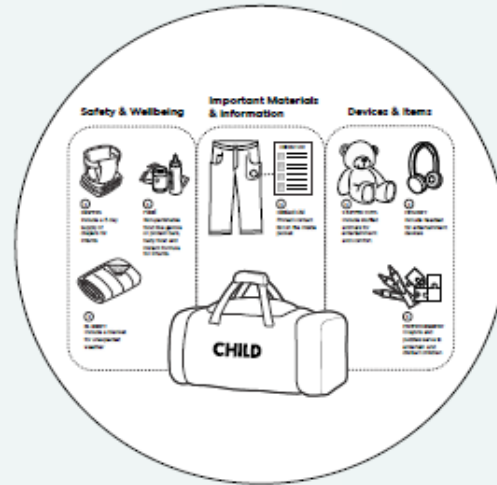

Chapter 6: Household Preparedness

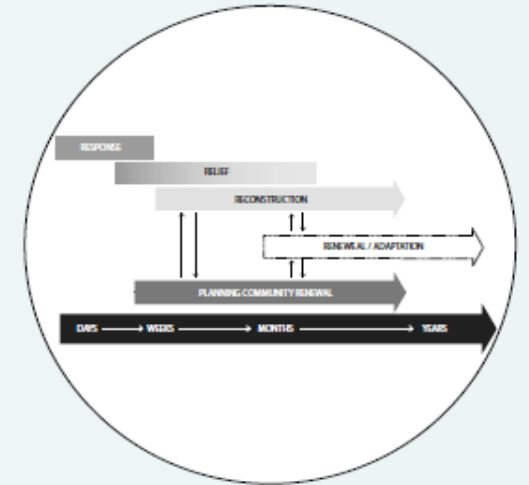

Chapter 7: Community Engagement



KEEP SAFE *Miami*

ARE YOU READY TO RESPOND?

Disaster can strike at any time, and a poorly managed response can put property and lives at risk.

This Toolkit equips **multifamily affordable building owners & managers** with a plan to address crisis.



Watch the video or scroll down to learn more.



The smaller photograph shows what
immediately after Hurricane Sandy.
The New York Times



Fannie Mae

**BELLWETHER
ENTERPRISE**



Enterprise



Building Resilient Housing



Funding

Affordable Housing
Mitigation and Adaptation
Operations
Staffing Capacity



Technical Assistance

Identifying Risk
Finding Solutions
Building Capacity to Respond



Stronger Infrastructure

Stable Grid
Resilient Systems



Planning

Participatory
Equity at Forefront
Model sharing

Laurie Schoeman
National Director, Resilience and Disaster Recovery
lschoeman@enteprrisecommunity.org

